



Real-time IoT-based Water Quality Monitoring System with Predictive Analytics for Sustainable Inland Fisheries in the Philippines

Liezl Asis¹

Arvin R. de la Cruz², PhD, ORCID No. 0000-0001-7325-5301

¹Doctor of Philosophy in Computer Engineering, Polytechnic University of the Philippines, Sta. Mesa, Manila, Philippines

²Program Chair, PhD and MS Computer Engineering, Polytechnic University of the Philippines, Sta. Mesa, Manila, Philippines

Article History:

Initial submission:	12 August 2025
First decision:	15 August 2025
Revision received:	16 March 2026
Accepted for publication:	20 March 2026
Online release:	27 March 2026

Abstract

Inland fisheries provide food and livelihood to 1.9 million Filipinos, contributing 51.8% of national fisheries production. This sector has positioned the Philippines as the sixth-largest aquaculture producer globally. However, recurring fish kills in Philippine lakes during 2023–2024 have highlighted critical water quality management challenges. This study enhances the sustainability of inland fisheries by developing a real-time water quality monitoring system with IoT technology that sends data to the backend for data analytics integration. The system achieved comparable accuracy to commercial multiparameter devices. A developmental research design was employed to develop a system that could be used in effective water quality monitoring. A quantitative research method was used in data collection. The system monitors the water quality parameters such as pH, dissolved oxygen, and temperature. Machine learning models were developed for predictive analytics to forecast water quality trends. Prescriptive analytics have been added to recommend actions when the water quality status is not normal. Water samples from different lakes were used in testing the system and ISO/IEC standards were used during the evaluation. The system achieved 99.39% accuracy for temperature, 94.97% for pH, and 80.67% for dissolved oxygen measurements.

Keywords: IoT-based water quality monitoring; predictive analytics; inland fisheries sustainability; machine learning models; Philippine aquaculture



Copyright © 2026. The Author/s. Published by VMC Analytik's Multidisciplinary Journal News Publishing Services. Real-time IoT-based Water Quality Monitoring System with Predictive Analytics for Sustainable Inland Fisheries in the Philippines © 2026 by Liezl Asis and Arvin R. de la Cruz is an open access article licensed under [Creative Commons Attribution \(CC BY 4.0\)](https://creativecommons.org/licenses/by/4.0/). This permits the copying, redistribution, remixing, transforming, and building upon the material in any medium or format for any purpose, even commercially, provided that appropriate credit is given to the copyright owner/s through proper and standard citation.

INTRODUCTION

Inland fisheries in the Philippines encompass fish extraction from lakes, ponds, rivers, and reservoirs (FAO, 2025). The Bureau of Fisheries and Aquatic Resources (BFAR) is the government agency responsible for the development, improvement, management, and conservation of fisheries and aquatic resources in the Philippines, operating under the Department of Agriculture (DA).

In the Philippines, inland fisheries are crucial in providing food and livelihoods to millions of people. According to the Fisheries Situation Report by the Philippine Statistics Authority (PSA) from January to March 2025, aquaculture production was recorded at 573.28 thousand metric tons, a 4.9% increase from the same period in 2024. The aquaculture subsector, which includes inland fisheries, accounted for

the largest share of 57.0% of the total fisheries production during the quarter (Fisheries Situation Report, January to March 2025, 2025). The Philippines was also ranked sixth among aquaculture-producing nations worldwide (Wee, 2019).

However, multiple fish kill incidents between 2023–2024 have highlighted critical water quality challenges. Recent fish kill incidents across Cavite (November 2023), Taal Lake (July 2023), Lake Sebu (January 2023), and CamSur Lake (November 2023) were uniformly attributed to dissolved oxygen depletion, demonstrating the urgent need for real-time monitoring systems (Montemayor, 2023; Mallari Jr., 2023; Calipay, 2023; Rebollido, 2023).

The integration of data analytics in real-time water quality monitoring has the potential to provide a more efficient and proactive approach

to managing inland fisheries. This could be achieved by real-time data collection and analysis through an Internet of Things (IoT) technology that could collect data and send it to the backend system where data analysis would be performed to understand better the data that have been collected and this could support data-driven decision-making. Integrating data-driven solutions could help promote the sustainability of inland fisheries and maintain the health of the aquatic ecosystem. This study hypothesizes that an IoT-based real-time monitoring system integrated with predictive analytics will achieve accuracy comparable to commercial devices (>90%) while providing proactive alerts absent in current monitoring practices.

This research develops and validates an IoT-based system, together with data analytics, to enhance the water quality monitoring system of inland fisheries in the Philippines. This would also provide an overview of the current state of the water quality monitoring in the Philippines and identify how this could be improved to make it more data-driven and eventually promote the sustainability of inland fisheries. Specifically, this study aims to:

1. Design and develop a real-time IoT-based water quality monitoring system.
2. Integrate predictive analytics for forecasting water quality parameters.
3. Validate system accuracy against commercial multiparameter devices.
4. Evaluate system usability using ISO/IEC 25010 standards.

Conceptual Framework. The study utilized the input-process-output (IPO) to describe the activities in product development. The input consists of the hardware components that would be used for the prototype. The process includes several activities that were conducted to develop the system, while the output of the research consists of different systems that make-up the whole product. The feedback is for

recommendations or suggestions, which came from the evaluation results, to improve the system. Figure 1 below shows the IPO model.

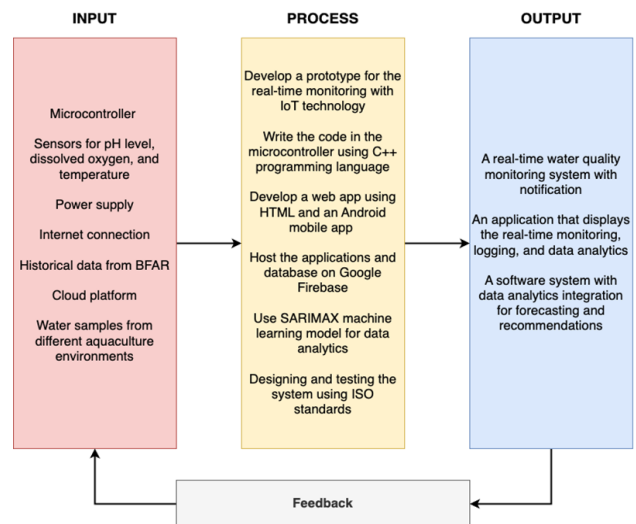

Figure 1
The Input-Process-Output model of the conceptual framework

LITERATURE REVIEW

This section synthesizes relevant literature on water quality monitoring systems and data analytics applications in aquaculture. A need for a real-time water quality monitoring system with data analytics integration has been identified to improve the efficiency and sustainability of fishery waters used in the aquaculture industry. Previous studies by Abdallah et al. (2023) have identified the need for real-time monitoring systems with integrated analytics.

Challenges in aquaculture sector. The aquaculture sector in the Philippines encounters numerous challenges. These obstacles encompass pests and diseases, deterioration of water quality, harmful algal blooms (HABs), and insufficient capital and government assistance (Tahiluddin & Terzi, 2021). Mendoza et al. (2022) conducted research about the drivers behind the decline in fish catch in Laguna Lake. This includes the increase of invasive species such as clown featherback and catfishes, the loss of fish habitat that's caused by the decline of aquatic plants and high

levels of chlorine, increased water turbidity, pollution, and fish kills. These challenges caused massive fish kills and gave rise to the need for a water quality monitoring system that could be used to determine the water quality in fishery waters.

Development of real-time water quality monitoring systems. Table 1 presents a comparative analysis of real-time water quality monitoring systems, highlighting their parameters, accuracy, and limitations. Bokington and Llantos (2017) designed a mobile-based system that focused on monitoring water temperature, a key factor influencing dissolved oxygen levels. Their low-cost solution provided aquaculture farmers with accurate, real-time data to maintain optimal conditions and prevent fish distress. However, the limitation of monitoring temperature alone was evident, as dissolved oxygen depletion continued to cause fish kills. To address broader needs, Demetillo et al. (2019) developed a wireless sensor network (WSN) capable of monitoring dissolved oxygen, pH, and temperature across large coverage areas. Their system stored real-time data and sent SMS alerts to managers and authorities, ensuring timely interventions at reduced costs.

Table 1
Comparison and analysis of literatures related to development of real-time water quality monitoring systems

Researcher	Features	Parameters	Accuracy	Limitations
Bokington and Llantos (2017)	Sensing layer, a network layer, a middleware layer, and an application layer.	Temperature	Can acquire data in the remote and real-time detection of water temperature	Only monitor temperature
Demetillo et al. (2019)	Utilized a wireless sensor network (WSN), SMS notifications	Dissolved oxygen (DO), pH, and temperature	Can measure and store real-time information, suitable for large coverage areas	Requires network coverage
Harun et al. (2017)	Uses Arduino	Dissolved oxygen (DO), pH, and temperature	Real-time monitoring and automation system, reduces operating costs	Requires internet access

Harun et al. (2017) further advanced monitoring by integrating automation into fishpond operations. Using Arduino, their system measured temperature, pH, and dissolved oxygen while controlling aeration and water supply pumps. This reduced reliance on manual labor, lowered operational expenses, and

improved efficiency. Collectively, the studies in Table 1 emphasize that while single-parameter systems provide valuable insights, multi-parameter monitoring systems that integrate affordability, automation, and communication technologies are more effective in sustaining water quality and supporting aquaculture productivity.

Using IoT technology in monitoring. Table 2 provides a comparative analysis of IoT-based water quality monitoring systems, showcasing their features, parameters, and limitations. Chen et al. (2022) developed an IoT system for fish farms that measured pH, dissolved oxygen (DO), water level, and temperature, with advantages such as low power consumption, multitasking, and improved processing time. Their design included a robotic arm for sensor cleaning, ensuring accuracy. Abdallah et al. (2023) created a real-time IoT system for fish farming that monitored pH, DO, total dissolved solids (TDS), and temperature, outperforming commercial devices in accuracy, though limited by inaccessible power sources. Pasika and Gandla (2020) applied IoT for drinking water monitoring, measuring pH, turbidity, water level, temperature, and humidity, with data transmitted to the cloud via ThingSpeak. Kasu et al. (2023) focused on aquaculture health, using sensors for turbidity, soil moisture, and gas levels.

Table 2
Comparison and analysis of literatures related to IoT technology

Researcher	Features	Parameters	Accuracy	Limitations
Chen et al. (2022)	Robotic arm	pH, DO, water level, temperature	Can complete maintenance actions and automatic measurements	Costly
Abdallah et al. (2023)	Microcontroller connected to sensors, actuators, and communication module	pH, DO, TDS, temperature	Outperforms commercial devices	Inaccessible power source
Pasika and Gandla (2020)	Allow devices to connect and share data, uses cloud	pH, turbidity, water level, temperature, humidity	Can monitor the quality of drinking water	Limited parameters
Kasu et al. (2023)	Used sensors	turbidity, soil moisture, gas levels	Allows continuous, real-time monitoring of water quality	Absence of proactive monitoring
Sekhwela et al. (2021)	Notification feature, mobile and portable system	pH, nitrate, turbidity, water level	Can monitor the water quality stored in the reservoir	Absence of real-time monitoring

Despite these advances, challenges remain in proactive monitoring, as sudden water quality changes often lack defined corrective actions. Sekhwela et al. (2021) addressed this gap with a portable IoT system connected to smartphones,

measuring pH, nitrate, turbidity, and water level, and offering notification features.

Beyond IoT, predictive analytics has emerged as a complementary solution to enhance water quality monitoring. Veerendra et al. (2023) combined remote sensing, GIS, and machine learning tools (MLT) to forecast surface water quality, aiming for better resource management. Rahu et al. (2024) integrated IoT and machine learning for agricultural irrigation, using regression models to predict water quality and comparing canal suitability for farming and fishing. Ghosh et al. (2023) applied machine learning models, particularly random forest, to distinguish drinkable from non-drinkable water based on parameters like pH, DO, BOD, and RDS. Bokonda et al. (2020) reviewed 30 studies, highlighting random forest and decision tree methods as widely used for predictive analysis. Sghir et al. (2022) extended predictive analytics to education, emphasizing the importance of selecting optimal tools and methods for forecasting outcomes. Shmueli and Koppius (2010) outlined six roles of predictive analytics in information systems research, including theory generation and model improvement, stressing the predictive power of empirical models. Maramba and Smuts (2024) reviewed predictive analytics in healthcare, noting its underutilization during the COVID-19 pandemic despite its potential to strengthen strategies.

Collectively, these studies demonstrate that IoT systems provide real-time, multi-parameter monitoring capabilities, while predictive analytics enhances proactive management by forecasting water quality trends. Chen et al. (2022), Abdallah et al. (2023), and Kasu et al. (2023) highlight IoT's role in aquaculture, while Pasika and Gandla (2020) and Sekhwela et al. (2021) extend applications to drinking water and reservoirs. Meanwhile, Veerendra et al. (2023), Rahu et al. (2024), and Ghosh et al. (2023) show how machine learning models can predict water quality outcomes, reducing risks of sudden degradation. Reviews by Bokonda et al. (2020), Sghir et al. (2022), Shmueli and Koppius (2010), and Maramba and Smuts (2024) emphasize the

broader applicability of predictive analytics across sectors, from education to healthcare. Together, IoT and predictive analytics form a powerful synergy: IoT provides continuous data streams, while predictive models transform these into actionable insights, ensuring sustainable water resource management and improved aquaculture productivity.

Applications of predictive analytics. Veerendra et al. (2023) combined remote sensing, GIS, and machine learning tools to forecast surface water quality, aiming for effective resource management. Rahu et al. (2024) integrated IoT and machine learning into a framework with modules for sensing, coordination, data processing, and decision-making, using regression models to predict water quality and comparing canal suitability for irrigation and fishing. Ghosh et al. (2023) emphasized environmental and health protection by applying machine learning models, particularly random forest, to distinguish drinkable from non-drinkable water based on parameters such as pH, DO, BOD, and RDS. Bokonda et al. (2020) provided a broad review of 30 studies, identifying random forest and decision tree methods as the most widely used for predictive analysis. These works collectively highlight the growing role of predictive analytics in water resource management, offering proactive solutions to sudden changes in water quality.

Beyond water management, predictive analytics has been applied across multiple sectors. Sghir et al. (2022) explored predictive learning analytics in education, showing how machine learning and deep learning models can forecast academic outcomes and support student learning. Shmueli and Koppius (2010) emphasized predictive analytics in information systems research, outlining six roles such as theory generation, model improvement, and evaluating real-world predictability, concluding that empirical models provide the highest predictive power. Maramba and Smuts (2024) assessed predictive analytics in healthcare, noting its underutilization during the COVID-19 pandemic despite its potential to strengthen strategies against crises. Together, these

studies demonstrate that predictive analytics, whether applied to water quality, education, information systems, or healthcare, provides valuable foresight and decision-making support. Its integration with IoT and machine learning enhances accuracy and responsiveness, making it a vital tool for sustainable resource management and broader societal applications.

Studies on prescriptive analytics. Frazzetto et al. (2019) published a paper on prescriptive analytics, emphasizing that predictive analytics is a crucial emerging technology for business analysts. The paper highlights how prescriptive analytics supports decision-making and bridges the gap between data and decisions.

A study was conducted on the strategies and techniques of prescriptive analytics by Lepenioti et al. (2019). The paper delved into the life cycle and the current research obstacles in the realm of prescriptive analytics. It also suggested that applications for prescriptive analytics are typically developed in a makeshift manner with limited adaptability for modern enterprises. Moreover, the lack of seamless integration between predictive analytics and prescriptive analytics hampers the maximization of big data's full potential.

A study on the various uses of prescriptive analytics was carried out by Poornima and Pushpalatha (2020). According to the researchers, prescriptive analytics helps users find the best solution to a problem and select the optimal decision from among different options. Prescriptive analytics can be utilized in a range of fields, including data delivery in streaming networks, research and development, health analysis, electrical power grids, clinical research, information integration, sales challenges, business processes, knowledge repositories, synthetic data, SCADA systems, and additive manufacturing.

Using ISO/IEC Standards. To test the system, certain standards must be considered. Some of these standards include ISO/IEC 25010 and ISO 5725-4:2020. Estdale and Georgiadou (2018)

presented a paper at the European Conference on Software Process Improvement on how to use ISO/IEC 25010, which provides leading models for assessing software products. The paper examines the scope and interpretation of the standard and identifies other significant aspects of product quality requirements and software evaluation.

Another study has been published about the implementation of an evaluation scheme using the ISO/IEC 25010 quality model standard. The research indicates that there were challenges related to evaluating the quality and effectiveness of software products. The proposed solution is to utilize the standard in the assessment of the products (Trichkova-Kashamova, 2021).

Fridman (2011) discussed the methodology of ensuring measurement accuracy using ISO 5725 standards. Deldossi and Zappa (2008) evaluated measurement uncertainties in ISO 5725 and GUM from a statistical perspective. While existing studies demonstrate various approaches to water quality monitoring, none have integrated real-time IoT monitoring with predictive analytics specifically for Philippine inland fisheries. This research addresses this gap by developing a comprehensive system validated against commercial standards.

METHODS

This study employed a developmental research design (Richey & Klein, 2007). The engineering design process was applied to ensure systematic development. This study applied the engineering design process in the development of a water quality monitoring system with the integration of data analytics. This process ensures that the solution is efficient, effective, and meets the requirements to solve the defined problems.

The proponents used the engineering design process as their system development method for their design. Problem identification and definition. In this step, the problem of inadequate water quality monitoring in inland

fisheries was identified and defined, considering the existing methods and limitations. The goal of this step was to identify the specific requirements for the water quality monitoring system. Requirements gathering and analysis. This involved collecting data and information from stakeholders, including fish farmers and government agencies, to understand the needs and requirements for the water quality monitoring system. This information was analyzed to determine the key features and functions that need to be included in the system. Concept development and prototyping. This step involved developing the concept for the water quality monitoring system, considering the requirements gathered in the previous step. A preliminary prototype was created to help validate the concept and ensure that it meets the requirements. System design. In this step, the details of the water quality monitoring system were designed, including hardware, software, and network components.

performance and user experience. This also included the changes to the hardware, software, analysis, or overall design of the system. Deployment and maintenance.

Finally, the water quality monitoring system was deployed and maintained to ensure that it continues to operate effectively and provide accurate water quality data for the inland fisheries. This consisted of regular updates and maintenance to the system, as well as user training and support.

Sampling Sites. To test the prototype, water samples were collected from different water sources such as Manila Bay, Taal Lake, and Laguna de Bay. A testing was also done together with BFAR, IT experts, and fish farmers, for the prototype to be tested by experts. A request was sent to BFAR to conduct water quality testing. An appointment was set to go to Manila Bay, around Navotas and Cavite areas, to collect water samples.

Data Gathering. To proceed with the development, the quantitative data collection method was used by collecting data from secondary data analysis, interviews, experiments, and observations. Gathering the information took several steps to ensure the success of the study.

First, the related literature and studies were looked up to determine what and why there is a need to develop a real-time water quality monitoring system. News articles were also gathered to see the main problems that the aquaculture industry in the Philippines was facing. These literature and studies were reviewed to see which would be significant for the research that was being performed.

An interview was conducted to determine what were the main physical water quality parameters that BFAR was using in determining the water quality in inland fisheries. The data coming from BFAR was used to decide which water quality parameters would be used in developing the system. It was concluded that the parameters pH level, dissolved oxygen, and

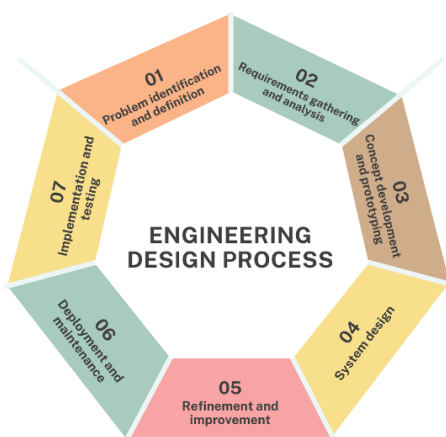

FIGURE 2
Engineering Design Process

The design considered the features and functions identified in the previous steps, as well as the available resources. Implementation and testing. This included the development and deployment of the water quality monitoring system, including the mobile application. Testing would be conducted to ensure that the system meets the requirements and performs as expected. Refinement and improvement. Based on the results of testing, the system was refined and improved to enhance its

temperature would be used as the main parameters that would be measured by the system.

Historical water quality data (2018–2023) were obtained from BFAR Region IV-A through the electronic Freedom of Information (e-FoI) portal, comprising monthly measurements of pH, DO, and temperature from Taal Lake. Water samples were collected from the three sampling sites at 0.5m depth using sterile containers. Power analysis for paired t-tests were conducted to determine the minimum sample size using SPSS v.26 with $\alpha=0.05$, power of 0.80, and effect size of 0.8. The analysis showed that 15 paired samples were needed to have enough power to detect an effect. To accommodate comparisons in all three sampling sites, an increased sample size of 30 (10 per site) was utilized.

This study was approved by the Bureau of Fisheries and Aquatic Resources (BFAR) and the testing was done together with BFAR officials. The Graduate School Research Ethics Committee (GSREC) of the Polytechnic University of the Philippines has also approved the ethics application form of this research.

When the development of the system started, a series of tests were done to see if the functionalities meet the requirements of the system. The agile methodology was used during the development to divide the project into smaller phases so that changes could easily be adapted. After completing the system development, more testing and experiments were carried out together with prospective users and experts in the field. This helped in checking the usability of the system and seeing whether it achieved the objective set in the research.

Functional Block Diagram. To come up with a feasible and working machine a block diagram was designed to show a high-level overview of how the components were connected. The prototype design as shown in Figure 3 includes the main hardware components that make up the system, such as microcontroller, power

supply, and sensors. The power supply and buck converter were responsible for providing the correct voltage to the components in the circuit.

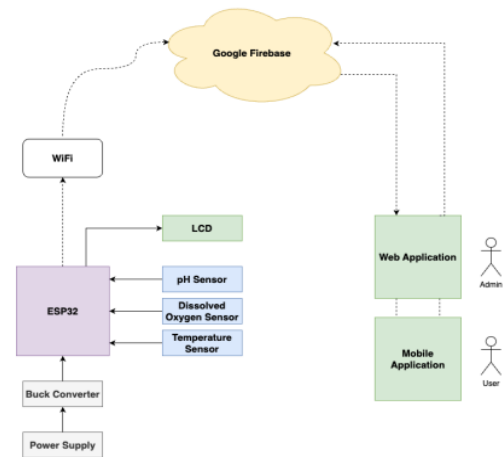

Figure 3
Functional Block Diagram of Utilizing Data-Driven Approaches for Water Quality Monitoring in Inland Fisheries

The sensors are sending the collected data to the microcontroller (ESP32). The data can be viewed on the prototype through the LCD screen. Wi-Fi is necessary to enable IoT integration in the system and provide internet connectivity. The data gathered by the sensors would pass through the network and send them to the server that was hosted in the cloud. Firebase was used to host the applications, manage the database, and set up the authentication of the system. The web application is accessible by the admin or anyone who has the right privileges, while the mobile application is accessible by the users.

Software Application. The Internet of Things (IoT) technology and the ISO standard ISO/IEC DIS 30141 were used to develop a prototype that could monitor the water quality in real-time and, at the same time send the collected data to a backend system for monitoring, logging, and analysis.

Figure 4 shows the basic design draft of the user interface for the web application and mobile application. It displays the latest data for the pH, dissolved oxygen, and temperature. It shows the status of either Normal (green) or

Warning (Red). The prescriptive analytics part shows the recommended actions to take. There's also logging available for the data collected every 30 minutes. Below is a line graph for the logs of the water parameters.

A web application and a mobile application were developed to show the real-time data coming from the prototype. The IoT technology helped in sending the real-time data to the backend system. The web app is accessible using the URL <https://aquaphil-insights.web.app/>. The login page looks like the one shown in Figure 4. The admin and users have different credentials that could be used to log on to the application. The mobile app can be accessed by first downloading the Android package and installing it on any Android device.

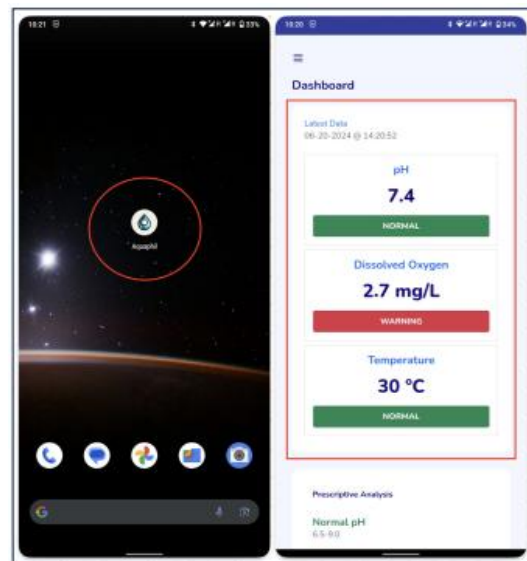

Figure 6
Main dashboard on the mobile application

Figure 6 shows the Aquaphil app installed on an Android mobile phone and the main dashboard once it's accessed. It presents the latest data of the real-time data being collected from the prototype. The values shown are similar to the ones available on the prototype and the web app.

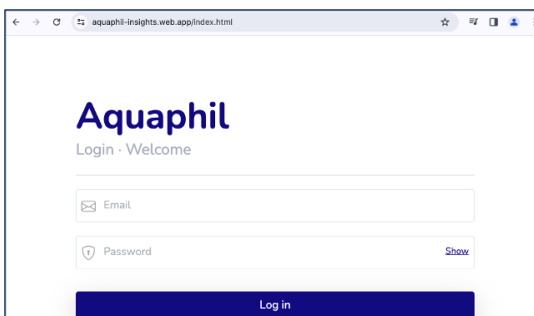

Figure 4
Login page of the application

Figure 5 shows the main dashboard of the real-time water quality monitoring system. It shows the date and time when the monitoring is happening. The real-time data of the physical water quality parameters such as pH, dissolved oxygen, and temperature, are also available on the page. The values being displayed on the LCD screen will also be displayed on the app.

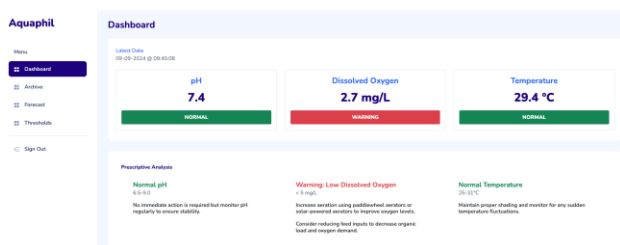

Figure 5
Main dashboard of the real-time water quality monitoring system

Hardware Components. There were three main sensors used in the prototype: an analog pH sensor, an analog dissolved oxygen sensor, and a temperature sensor. The ESP32 Wi-Fi IoT development board was the microcontroller used in order to configure the functionality of the prototype. The ISO/IEC/IEEE 8802-11:2022 standard was used for the wireless communication of the system.

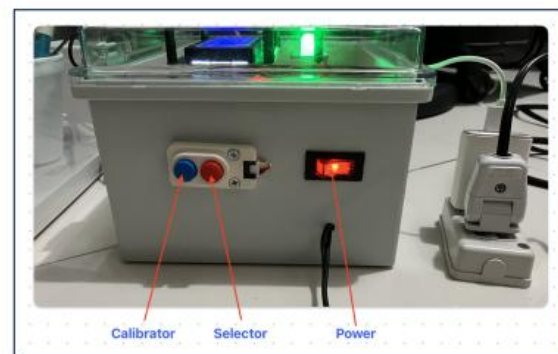

Figure 7
Functional buttons of the prototype

There were buttons on the right side of the prototype as shown in Figure 7. The power button is used to turn on or off the prototype. The blue button was used as a calibrator when the user needed to calibrate the sensors. While the red button was used as a selector, based on what's displayed on the LCD screen.

Figure 8 shows the image of the actual prototype. The main components consist of a microcontroller, meter kits, sensors measuring the temperature, pH level, and dissolved oxygen, the LCD that displays the measured data, a light indicator to show the status of the parameters, and a power supply.

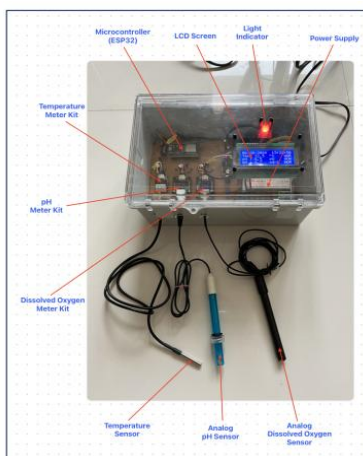

FIGURE 8
The water quality monitoring prototype

Machine Functionality. To have a better overview of the circuit design, refer to the schematic diagram in Figure 9. This was designed to show how the main components were connected. The ISO/IEC 30141:2018 standard was used for the IoT reference architecture of the system.

Figure 9 is the schematic diagram of the water quality monitoring device. This was designed using the open-source software KiCad which is a tool used for designing and creating printed circuit boards.

The ESP32 microcontroller has pins that are connected to almost all the other components in the circuit. This was used mainly for the IoT functionality because it's integrated with Wi-Fi

and Bluetooth. At the top of the diagram, there's a power supply and a buck converter. The power supply comes from an electric socket, and the buck converter was used to convert the voltage to match what's needed by the device and its components. The power source supplies a 220V voltage, while the operating voltage of the components in the circuit ranges between 2.2V and 3.6V.

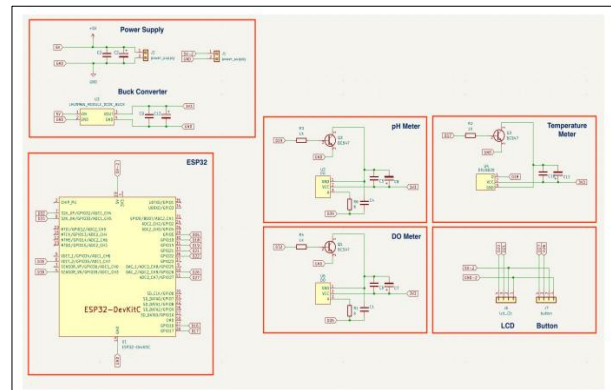

FIGURE 9
Schematic Diagram of the Water Quality Monitoring Device

The sensors or probes were some of the main components of the device. They were used for data gathering of water quality parameters such as temperature, pH, and dissolved oxygen. This data goes through the ESP32 microcontroller that would do the initial processing of data that would then be sent to the cloud. The microcontroller was used for customizing the program that was used for this device to set and control its functionalities.

Reference Device. During the testing with BFAR, they demonstrated how they use the YSI ProDSS multi-parameter water quality meter. It measures several water quality parameters, it is portable and rechargeable, and the probe is long enough to go a few meters deep in the fishery water source. The only downside of this device is that it does not have a software counterpart where the users can see real-time water quality monitoring. However, since it is a commercial product and measures multiple water quality parameters, it was ideal to test different parameters that could affect the water quality changes.

RESULTS

System Evaluation. Table 3 presents the evaluation scores from BFAR officials, IT experts, and fish farmers (n=34). Mean scores ranged from 4.82 to 5.00 (SD = 0.06), with no significant differences between evaluator groups ($F(2,31) = 0.822, p > 0.05$).

Functional sustainability focuses on whether the system provides the necessary functionalities described in the system, produces accurate results, and effectively supports users in monitoring the water quality and performing data analysis. The functionality shows the overall features that both the system and prototype can do as described during the demonstration of how it works and based on how it was designed. It acquired an average score of 4.97. The evaluators think that the system could do its functions as expected. Performance efficiency received a score of 5.0 and it's about whether the prototype operates efficiently under various environmental conditions or not, and if it responds well to real-time monitoring. It's about making sure that the system still works even though there are external factors that could affect the performance of the system. It also includes the performance of the applications when being used during the water quality monitoring.

Compatibility measures if the system can operate efficiently alongside other software and hardware components and if it integrates well with other systems used in water quality monitoring and data analytics.

This quality received a score of 4.94. In this research, several features were added that range from the hardware prototype, IoT, sensor calibration, microcontroller configuration, web and mobile applications, and data analytics used for forecasting and recommendations of actions. This ensures that the hardware, software, and analytics are well-connected and compatible with each other to perform their intended usage.

Table 3
Average rating of the system quality characteristics

Quality Characteristics	Average Rating
1. Functional Suitability Does the system provide all necessary functionalities, produce accurate results, and effectively support users in monitoring water quality and performing data analysis?	4.97
2. Performance Efficiency Does the prototype operate efficiently under various environmental conditions? Does it respond well to real-time monitoring?	5.00
3. Compatibility Could the system operate efficiently alongside other software and hardware, and integrate well with other systems used in water quality monitoring and data analytics?	4.94
4. Usability Is the system easy to recognize, learn, and use? Does it provide a pleasing and accessible user interface?	5.00
5. Reliability Could the system tolerate faults and recover from crashes or disruptions effectively? Was the hardware robust and reliable in continuous operation?	4.97
6. Security How well does the system protect data confidentiality, integrity, and authenticity? Could it ensure accountability of user actions?	4.82
7. Maintainability Is the system modular and easy to modify, diagnose, test, and reuse components? Could it be easily repaired and upgraded?	4.97
8. Portability How easily could the system be adapted to different environments, installed, and replaced by other software and hardware used in water quality monitoring and data analytics?	4.85
9. Safety How safe is it to use the system during operations? Is the system still usable when there is a failure?	4.88

Usability is about how easy it is to recognize, learn, and use the system. It's also about the user interface/user experience when using the applications. This quality characteristic acquired a score of 5.00. The prototype operations manual and the application user's manual were both provided. Proper training would be needed to operate the prototype to ensure that it would be used correctly. Proper calibration is needed for the sensors to work properly, especially when they haven't been used for a long period. Based on the feedback from the users, the application is easy to navigate and understand how it's used.

Reliability shows if the system can tolerate faults and recover from crashes or disruptions effectively and if the hardware is robust and reliable in continuous operation. This garnered a score of 4.97. The circuit in the prototype was attached properly to the enclosure to make sure that it didn't move around during transport, and it stayed intact even after shaking it. The applications are hosted in the cloud so there's no physical server needed to manage them. The cloud platform is also easily accessible via the Internet so it's easy to troubleshoot and make changes on the applications.

Security shows if the system could protect data confidentiality, integrity, and authenticity and if it could ensure accountability of user actions. This characteristic got a score of 4.82. All the data gathered were saved in the database that's also hosted in Firebase. Only the researcher has developer access to the cloud and access to the platform is protected with multi-factor authentication. The data of the people who evaluated the system were also kept and were not shared anywhere online for data privacy.

Maintainability refers to the system's modularity and ease of modifying, diagnosing, testing, and reusing components. It could also be easily repaired and upgraded. This got a score of 4.97. For this characteristic, the components used in the prototype are easily available from electronics shops. The calibration of the sensors ensures that they produce accurate results during monitoring.

The sensors can also be kept when not in use to prevent anything from damaging them. It's also easy to troubleshoot the application because it's accessible online if there's an internet connection. IoT is a crucial part of the system because the calibration and sending of data collected to the backend relies on it.

Portability tackles how easily the system could be adapted to different environments, installed, and replaced by other software and hardware used in water quality monitoring and data analytics. This characteristic got an average score of 4.85. During the testing with BFAR, they suggested making the prototype more portable so that it's easy to bring it on-site during field testing. They also advised making the prototype water-resistant so that it doesn't get damaged when exposed to fishery water.

Safety is about the capability of a product under defined conditions to avoid a state in which human life, health, property, or the environment is endangered. The evaluation shows an average score of 4.88 for this quality characteristic. Users only have direct contact with the applications, which does not necessarily pose a danger to anyone. The risk that could be considered would be updating the prototype or calibrating the sensors. In the software, safety could be the operational constraint regarding the expectations of whether the data being accessed are safe and secure.

Accuracy of the System. The accuracy testing aims to evaluate the accuracy of the water quality monitoring system by measuring the dissolved oxygen, pH, and temperature, as compared to the commercial multiparameter device. This was conducted together with BFAR simultaneously while using the commercial multiparameter.

Table 4 shows the water samples used during testing collected from Manila Bay. There were ten trials done to compare the results between the prototype and BFAR's device. The results of the accuracy testing for Temperature measured in degree Celsius (°C). By getting the average of

the ten trials, the BFAR device has a temperature value of 31.0 and a 95% CI [30.81, 31.19], while the prototype has a value of 31.07 and a 95% CI [31.002, 31.14], and this resulted to an accuracy of 99.39%. The temperature measurements showed no significant difference from the commercial device ($t(9) = -0.79, p = 0.22$), indicating equivalent accuracy.

Table 4
Accuracy testing of Temperature (°C)

Trial No.	BFAR	Prototype	Accuracy %
1	31.2	31.1	99.68%
2	31.5	31.2	99.05%
3	31.3	31.2	99.68%
4	30.9	31.1	99.36%
5	30.7	31.1	98.71%
6	30.7	31.1	98.71%
7	30.8	31.0	99.35%
8	30.9	31.0	99.68%
9	31.0	31.0	100%
10	31.0	30.9	99.68%
Average	31.0	31.07	99.39%
LCL a	30.81	31.002	
UCL	31.19	31.14	

The accuracy testing of pH is presented in Table 5. Ten trials were conducted to measure the pH level using the commercial device used by BFAR and the prototype that was developed for this research. On average, the pH level using the BFAR device was 8.35 with a 95% CI [8.30, 8.39], while the prototype measurement was 7.95 with a 95% CI [7.48, 8.42]. This shows a 94.97% accuracy during the testing of pH. The result also shows that the pH sensor has high accuracy when compared to the commercial device, with the two devices having no statistically significant difference.

Table 5
Accuracy testing of pH

Trial No.	BFAR	Prototype	Accuracy %
1	8.36	6.3	75.36%
2	8.23	7.5	91.13%
3	8.28	7.8	94.20%
4	8.30	8.0	96.39%
5	8.32	8.1	97.36%
6	8.40	8.2	97.62%
7	8.4	8.3	98.81%
8	8.4	8.4	100%
9	8.4	8.4	100%
10	8.4	8.5	98.82%
Average	8.35	7.95	94.97%
LCL	8.30	7.48	
UCL	8.39	8.42	

Table 6 shows the accuracy testing conducted for the dissolved oxygen based on the unit mg/L. There were ten trials conducted using the BFAR commercial device and the prototype. The average of the trials shows that BFAR's device measures the dissolved oxygen at 5.88 mg/L with a 95% CI [5.79, 5.97], while the prototype's measurement was 4.83 with a 95% CI [4.33, 5.33], and this resulted in an average accuracy of 80.67%.

Table 6
Accuracy testing of Dissolved Oxygen (mg/L)

Trial No.	BFAR	Prototype	Accuracy %
1	6.11	6.6	92.58%
2	5.99	5.4	90.15%
3	5.92	5.0	84.46%
4	5.93	4.6	77.57%
5	5.97	4.5	77.57%
6	5.82	4.4	75.60%
7	5.79	4.4	75.99%
8	5.76	4.4	76.39%
9	5.76	4.5	78.13%
10	5.75	4.5	78.26%
Average	5.88	4.83	80.67%
LCL	5.79	4.33	
UCL	5.97	5.33	

The 80.67% accuracy for DO measurements and the confidence intervals showing no overlap require further investigation with properly calibrated reference devices. When it comes to dissolved oxygen, to consider that the prototype has high accuracy, it needs a 2-5% difference as the commercial device. The dissolved oxygen measurement can be justified by performing more testing where both the commercial device and the prototype are properly calibrated to show the actual results.

Using the standard ISO 5725-4:2020 – Accuracy (Trueness and Precision) of Measurement of Methods and Results, the accuracy of the system was calculated by comparing the values acquired from the commercial multiparameter used by BFAR and the data gathered when using the prototype.

Predictive Analytics. Figure 10 shows the predictive analytics or forecasts of what could be the possible water quality parameter values in Taal Lake in the next several months, starting October 2023. The highlighted columns were the

surface values of water temperature (C), pH, and dissolved oxygen (mg/L).

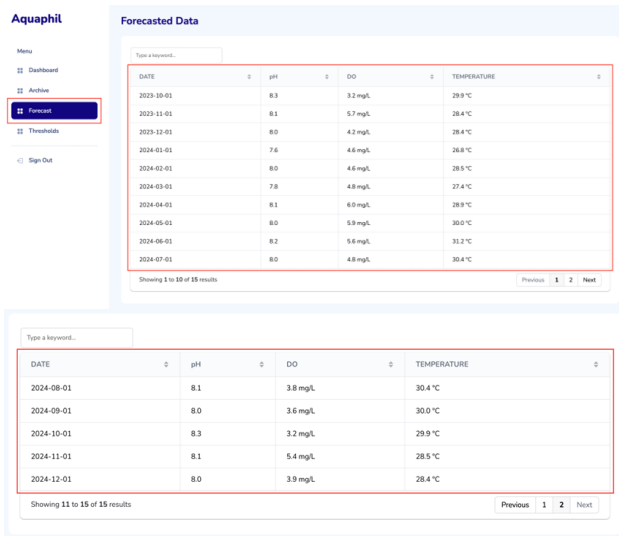

Figure 10
Forecasted Data using Predictive Analytics

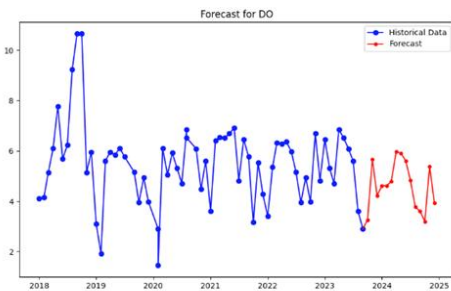

Figure 11
Graph of the Historical and Forecast Data for Dissolved Oxygen

Figure 11 shows the graph of the historical and forecast data for dissolved oxygen. Figure 12 shows the graph for the historical and forecast data for pH. And Figure 13 shows the graph of the historical and forecast data for temperature. The blue line shows the historical data from BFAR from January 2018 to September 2023. The red line shows the forecasted data starting October 2023 to December 2024.

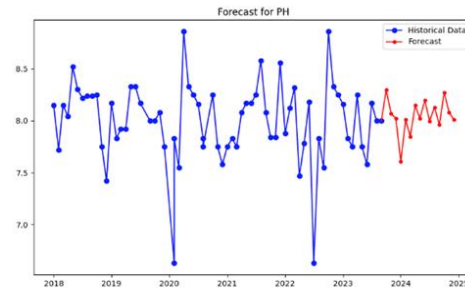

Figure 12
Graph of the Historical and Forecast Data for pH

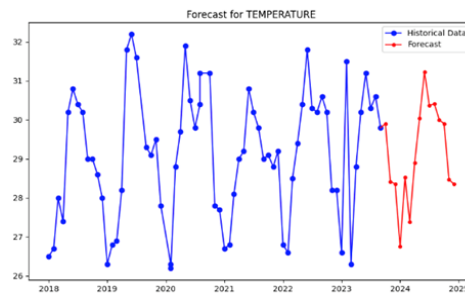

Figure 13
Graph of the Historical and Forecast Data for Temperature

Table 7
Actual Observed pH, DO, and temperature in Taal Lake

Date	pH	DO	Temperature
2023-10-17	8.6	6.3 mg/L	28.2 °C
2023-11-21	8.3	5.8 mg/L	27.0 °C
2023-12-12	8.4	6.6 mg/L	27.0 °C
2024-01-16	8.0	4.9 mg/L	25.8 °C
2024-02-13	7.7	1.4 mg/L	25.0 °C
2024-03-13	8.3	7.3 mg/L	26.0 °C
2024-04-17	8.9	10.1 mg/L	27.8 °C
2024-05-13	8.7	3.8 mg/L	29.2 °C
2024-06-10	9.0	8.9 mg/L	28.7 °C
2024-07-11	8.9	6.5 mg/L	31.0 °C
2024-08-14	9.0	8.5 mg/L	30.2 °C
2024-09-11	8.9	9.3 mg/L	29.5 °C
2024-10-09	8.8	7.6 mg/L	30.0 °C
2024-11-12	8.7	8.2 mg/L	28.7 °C
2024-12-04	8.6	5.6 mg/L	27.5 °C

Table 7 presents the actual observed pH, DO, and temperature in Taal Lake gathered by BFAR from October 2023 to December 2024. This dataset is used in the computation of the predictive model validation metrics, such as root mean square error (RMSE), mean absolute error (MAE), and coefficient of determination (R^2), which are used to evaluate the accuracy and effectiveness of the developed water quality monitoring device in generating good estimates of pH, DO, and temperature.

From the obtained results, the pH (RMSE = 0.630, MAE = 0.6, $R^2 = 0.279$) was more accurate than the DO (RMSE = 3.179, MAE = 2.8, $R^2 = 0.0002$), while temperature (RMSE = 1.452, MAE = 1.2, $R^2 = 0.642$) was found to be the most accurate among all parameters. The predicted pH values have low errors that are consistent, provided by the almost identical RMSE and MAE. However, the low R^2 indicates the device was unable to capture the underlying trend or pattern. With the DO, it had a very low R^2 , suggesting it has no predictive power while still having large errors. In contrast, temperature has a higher R^2 , making the device more reliable and accurate when predicting this parameter. Its RMSE is also higher than the MAE, which may indicate outliers.

DISCUSSION

The development of this real-time monitoring system addresses six critical challenges in Philippine inland fisheries. The first challenge addressed was the prevention of water quality degradation in inland fisheries by monitoring the physical water quality parameters such as pH, temperature, and dissolved oxygen. This study addresses the sudden water quality changes that caused millions of pesos in losses from fish kills during 2023–2024. This study also tackles the problem in promoting a proactive approach to water quality monitoring using Predictive Analytics. Water quality monitoring is currently only being done a few times every month by collecting water samples from the fish farms and testing them at the BFAR laboratory. Based on the five-year data gathered from the BFAR Region IV-A Batangas area, they have data once every month from January 2018 to September 2023..

The implementation of guided actions based on Prescriptive Analytics of the water quality of inland fisheries emerged as another significant challenge. The prescriptive analytics module provides actionable recommendations based on threshold violations. Since the system aims to provide a proactive approach when it comes to monitoring, prescriptive analytics was added in order to provide recommendations of possible actions that the fish farmers, stakeholders, and

other officials could take when the water quality parameters are on warning status. This also contributes to making data-driven decisions by the people managing the fish farms. Using predictive model validation metrics, it was found that temperature was the parameter that received the most accurate forecast, with pH being the closest to the actual average values, while DO has the least accurate prediction, suggesting either an unresolved issue in the system or that the actual data has no relationship with the forecast data. Challenges in guiding decision-making for sustainable inland fisheries through water quality monitoring with notification/alerting systems was also addressed. The system not only consists of a monitoring system, but also additional features such as alerting or notification system, logging, and archiving of the data. The notification is only available on the mobile app because it allows users to get the alerts whenever and wherever they are as long as they have the Android phone where the Aquaphil app was installed. It allows a proactive approach to knowing the water quality status and, at the same time taking the necessary action because they get the notification about it in real time.

Another critical challenge relates to the experimental testing of the water quality monitoring system using ISO/IEC 25010 standard considering its functionality, efficiency, compatibility, usability, reliability, security, maintainability, and portability. After collecting the water samples from Manila Bay, a demonstration of how the system works was conducted at BFAR headquarters together with BFAR officials. The presentation included showing how the prototype functions and how the applications work. There was also a discussion with BFAR for their questions and clarifications. The BFAR officials also did a demo on how their commercial multiparameter works to make a comparison with the prototype. The experimental testing done was also discussed previously. They were used to demonstrate to evaluators how the system works. The comparison of the prototype to the commercial multiparameter device used by

BFAR in terms of accuracy based on ISO 5725-4:2020 standard was lastly addressed. During the testing with BFAR, they demonstrated how they use the YSI ProDSS multi-parameter water quality meter. It measures several water quality parameters, it is portable and rechargeable, and the probe is long enough to go a few meters deep in the fishery water source. The only downside of this device is that it doesn't have a software counterpart where the users can see real-time water quality monitoring. However, since it is a commercial product and measures multiple water quality parameters, it's ideal to test different parameters that could affect the water quality changes. Compared to the existing device that BFAR uses, this real-time IoT water quality monitoring system costs way less to develop while still producing accurate results, which are comparable to the commercial multiparameter. Furthermore, this study contributes to the literature by demonstrating the successful integration of IoT and predictive analytics in resource-constrained aquaculture settings.

Study Limitations. The study acknowledges several important limitations that shape the interpretation of its findings. First, the sample size was restricted to only 30 water samples collected from three sites, which narrows the scope of generalization. In addition, the testing period was confined to a single season, meaning that seasonal variations in water quality could not be fully captured. Another constraint lies in the accuracy of the dissolved oxygen (DO) sensor, which was measured at 80.67% and indicates a need for further refinement to ensure more reliable readings. Finally, the predictive model used in the study was trained on a relatively limited dataset spanning just five years, which may affect the robustness and long-term applicability of its projections. Taken together, these limitations highlight the need for cautious interpretation of results and point to areas where future research can expand and strengthen the study's conclusions.

Conclusion. The study concludes that a real-time water quality monitoring system offers

significant potential in preventing water quality degradation by providing early warnings of parameter changes. The prototype demonstrated accuracy comparable to a commercial multiparameter device, while its notification system allowed users to receive immediate updates on water conditions. Beyond real-time monitoring, predictive analytics proved valuable in forecasting possible water quality trends over several months, enabling a proactive approach. Prescriptive analytics further enhanced the system by recommending actions when parameters exceeded normal thresholds, ensuring timely interventions.

Moreover, the system's design and performance were evaluated against ISO/IEC 25010 standards, confirming its functionality, reliability, usability, efficiency, maintainability, and portability. The Bureau of Fisheries and Aquatic Resources (BFAR) recognized the prototype's strong design and practical utility for inland fisheries monitoring. Accuracy testing under ISO 5725-4:2020 also validated the hypothesis that the system's results are comparable to BFAR's commercial devices. Overall, the integration of real-time monitoring, predictive and prescriptive analytics, and automated notifications positions the system as a valuable tool for fish farmers and stakeholders, reducing manual sampling and promoting proactive water management.

Recommendation. The BFAR and other evaluators provided several recommendations to further improve the water quality monitoring system and enhance its usability in real-world applications. One of the key suggestions was to make the prototype more portable, ensuring ease of use during on-site testing. To address challenges encountered in the field, they also advised adding a back-up battery, which would allow the system to function even when a power source is unavailable. Another enhancement proposed was the inclusion of a feature that lets users select different reading intervals, such as 5 seconds, 10 seconds, 30 seconds, or 1 minute, giving greater flexibility in monitoring frequency.

Additionally, the prototype should be made water-resistant by designing an enclosure that fully protects its components from moisture, preventing damage during field operations. Finally, expanding the system's capabilities by incorporating more parameters, such as conductivity, depth, carbon dioxide, and ammonia, was recommended to provide a more comprehensive assessment of water quality. Collectively, these improvements would strengthen the system's reliability, adaptability, and effectiveness, making it a more valuable tool for fish farmers, researchers, and stakeholders engaged in sustainable water resource management.

Future studies should maximize the data collected during testing to strengthen predictive analytics and forecasting capabilities. Expanding geographic and seasonal data collection across multiple regions, growing seasons, and onion varieties would improve the model's generalizability under diverse agro-climatic conditions. Integrating multi-modal information, such as weather parameters, soil conditions, and crop growth stages, could further enhance diagnostic accuracy, especially for visually similar disease classes. At the same time, adopting advanced lightweight architectures, including mobile-optimized attention mechanisms and compact vision transformers, is recommended to achieve stronger feature discrimination while maintaining deployment efficiency. Finally, conducting longitudinal user studies through extended field trials would provide valuable insights into sustained adoption, user learning, and long-term system effectiveness, ensuring that the model evolves into a robust and practical tool for agricultural monitoring.

Conflict of interest. The authors declare that the research was conducted without commercial or financial relationships that could be construed as a potential conflict of interest.

Funding source. This research received no external funding.

Artificial intelligence use. No AI tools were used in the preparation of this manuscript.

Ethics approval statement. This study was approved by the Polytechnic University of the Philippines Graduate School Research Ethics Committee.

Data availability statement. All data supporting the findings of this study are included within the manuscript and its supplementary materials.

Publisher's disclaimer. The views expressed in this article are those of the authors and do not necessarily reflect the views of the publisher. The publisher disclaims any responsibility for errors or omissions.

REFERENCES

- Abdallah, W., Mutairi, A., Kasim, M., & Al-Aubidy, K. (2023, June). IoT-based smart monitoring and management system for fish farming. *Bulletin of Electrical Engineering and Informatics*, 12(3), 1435–1446. <https://doi.org/10.11591/eei.v12i3.3365>
- Bokingkito, P. B., & Llantos, O. E. (2017). Design and implementation of Real-Time mobile-based water temperature monitoring System. *Procedia Computer Science*, 124, 698–705. <https://doi.org/10.1016/j.procs.2017.12.207>
- Bokonda, P. L., Ouazzani-Touhami, K., & Souissi, N. (2020). Predictive analysis using machine learning: Review of trends and methods. In 2020 *International Symposium on Advanced Electrical and Communication Technologies (ISAECT)* (pp. 1–6). IEEE. <https://doi.org/10.1109/isaect50560.2020.9523703>
- Calipay, C. (2023, November 22). Heavy rains trigger fish kill in CamSur Lake. *Philippine News Agency*. <https://www.pna.gov.ph/articles/1214132>

- Chen, C., Wu, Y., Zhang, J., & Chen, Y. (2022). IoT-Based Fish Farm Water Quality Monitoring System. *Sensors*, 22(17), Article 6700. <https://doi.org/10.3390/s22176700>
- Deldossi, L., & Zappa, D. (2008). ISO 5725 and GUM: comparison and comments. *Accreditation and Quality Assurance*, 14(3), 159-166. <https://doi.org/10.1007/s00769-008-0478-3>
- Demetillo, A. T., Japitana, M. V., & Taboada, E. B. (2019). A system for monitoring water quality in a large aquatic area using wireless sensor network technology. *Sustainable Environment Research*, 29(1), Article 12. <https://doi.org/10.1186/s42834-019-0009-4>
- Estdale, J., & Georgiadou, E. (2018). Applying the ISO/IEC 25010 quality models to software product. In X. Larrucea, I. Santamaria, R. O'Connor, & R. Messnarz (Eds.), *Communications in computer and information science* (pp. 492-503). Springer. https://doi.org/10.1007/978-3-319-97925-0_42
- Fisheries Situation Report, January to March 2025. (2025, May 6). *Philippine Statistics Authority*. <https://psa.gov.ph/content/fisheries-situation-report-january-march-2025>
- Frazzetto, D., Nielsen, T. D., Pedersen, T. B., & Šikšnys, L. (2019). Prescriptive analytics: a survey of emerging trends and technologies. *The VLDB Journal*, 28(4), 575-595. <https://doi.org/10.1007/s00778-019-00539-y>
- Fridman, A. E. (2011). Assurance of Measurement Accuracy in Compliance with ISO 5725 Standards. In *The Quality of Measurements* (pp. 179-195). Springer. https://doi.org/10.1007/978-1-4614-1478-0_8
- Ghosh, H., Tusher, M. A., Rahat, I. S., Khasim, S., & Mohanty, S. N. (2023). Water quality assessment through predictive machine learning. In V.E. Balas, V.B. Semwal, & A. Khandare (Eds.), *Lecture notes in networks and systems* (pp. 77-88). Springer. https://doi.org/10.1007/978-981-99-3177-4_6
- Harun, Z., Reda, E., & Hashim, H. (2018). Real time fishpond monitoring and automation using Arduino. *IOP Conference Series Materials Science and Engineering*, 340, Article 012014. <https://doi.org/10.1088/1757-899x/340/1/012014>
- Food and Agriculture Organization of the United Nations [FAO]. (2025). *Fishery and aquaculture statistics - Yearbook 2023*. Rome: FAO. <https://doi.org/10.4060/cd6788en>
- ISO/IEC 25010:2023. (2023). *ISO*. <https://www.iso.org/standard/78176.html>
- ISO 5725-4:2020. (2020). *ISO*. <https://www.iso.org/standard/69421.html>
- ISO/IEC DIS 30141. (n.d.). *ISO*. <https://www.iso.org/standard/88800.html>
- ISO/IEC/IEEE 12207:2017. (2017). *ISO*. <https://www.iso.org/standard/63712.html>
- ISO 19731:2017. (2017). *ISO*. <https://www.iso.org/standard/66187.html>
- ISO/IEC/IEEE 8802-11:2022. (2022). *ISO*. <https://www.iso.org/obp/ui/en/#iso:std:iso-iec-ieee:8802:-11:ed-3:v1:en>
- Kasu, S. A., Mathukumalli, S., Done, H., Yalavarthy, G., & Veeramalla, S. K. (2023). IoT-Based Real-Time Water Quality Monitoring in Aquaculture Systems Enhancing Aquatic Species Health. In B. Mishra (Ed.), *Intelligent Engineering Applications and Applied Sciences for*

- Sustainability* (pp. 406–424). IGI Global Scientific Publishing. <https://doi.org/10.4018/979-8-3693-0044-2.ch021>
- Lepenioti, K., Bousdekis, A., Apostolou, D., & Mentzas, G. (2019). Prescriptive Analytics: A survey of approaches and methods. In W. Abramowicz & A. Paschke (Eds.), *Lecture notes in business information processing* (pp. 449–460). Springer. https://doi.org/10.1007/978-3-030-04849-5_39
- Mallari Jr., D. T. (2023, July 18). *Fish kill hits Taal Lake anew; 343 metric tons of tilapia, 'bangus' turn belly up*. INQUIRER.net. <https://newsinfo.inquirer.net/1803117/fish-kill-hits-taal-lake-anew-343-tons-of-tilapia-bangus-turn-belly-up>
- Maramba, G., & Smuts, H. (2024). Predictive analytics A silver bullet for a pandemic – A systematic literature review. In L. Uden & I.H. Ting (Eds.), *Communications in computer and information science* (pp. 415–429). Springer. https://doi.org/10.1007/978-3-031-63269-3_32
- Mendoza, J. N., Prüse, B., Mattalia, G., Kochalski, S., Ciriaco, A., & Söukand, R. (2022). Fishers' Perspectives: the Drivers Behind the Decline in Fish Catch in Laguna Lake, Philippines. *MAST Maritime Studies/Maritime Studies*, 21(4), 569–585. <https://doi.org/10.1007/s40152-022-00287-w>
- Montemayor, M. (2023, November 16). *BFAR: Massive fish kill in Cavite caused by algal bloom*. Philippine News Agency. <https://www.pna.gov.ph/articles/1213792>
- Pasika, S., & Gandla, S. T. (2020). Smart water quality monitoring system with cost-effective using IoT. *Heliyon*, 6(7), Article e04096. <https://doi.org/10.1016/j.heliyon.2020.e04096>
- Poornima, S., & Pushpalatha, M. (2020). A survey on various applications of prescriptive analytics. *International Journal of Intelligent Networks*, 1, 76–84. <https://doi.org/10.1016/j.ijin.2020.07.001>
- Rahu, M. A., Shaikh, M. M., Karim, S., Soomro, S. A., Hussain, D., & Ali, S. M. (2024). Water Quality Monitoring and Assessment for Efficient Water Resource Management through Internet of Things and Machine Learning Approaches for Agricultural Irrigation. *Water Resources Management*, 38(13), 4987–5028. <https://doi.org/10.1007/s11269-024-03899-5>
- Rebollido, R. (2023, January 17). *Fish kill hits Lake Sebu, tilapia raisers lose P10M*. RAPPLER. <https://www.rappler.com/philippines/mindanao/fish-kill-lake-sebu-tilapia-raisers-lose-millions-january-2023/>
- Richey, R. C., & Klein, J. D. (2007). *Design and development research: Methods, strategies, and issues* (1st ed.). Routledge. <https://doi.org/10.4324/9780203826034>
- Sekhwela, D., Owolawi, P. A., Mapayi, T., & Odeyemi, K. (2021, February 1). Water Quality Monitoring with Notifications System. In *2020 2nd International Multidisciplinary Information Technology and Engineering Conference (IMITEC)* (pp. 1–6). IEEE. <https://doi.org/10.1109/imatec50163.2020.9334095>
- Sghir, N., Adadi, A., & Lahmer, M. (2022). Recent advances in Predictive Learning Analytics: A decade systematic review (2012–2022). *Education and Information Technologies*, 28(7), 8299–8333. <https://doi.org/10.1007/s10639-022-11536-0>

Shmueli, G., & Koppius, O. (2010). Predictive Analytics in Information Systems Research. *SSRN Electronic Journal*, 35(3), 553–572. <https://doi.org/10.2139/ssrn.1606674>

Tahiluddin, A., & Terzi, E. (2021). An overview of fisheries and aquaculture in the Philippines. *Journal of Anatolian Environmental and Animal Sciences*, 6(4), 475–486. <https://doi.org/10.35229/jaes.944292>

Trichkova-Kashamova, E. (2021, August 19). Applying the ISO/IEC 25010 Quality Models to an Assessment Approach for Information Systems. In 2021 12th National Conference with International Participation (ELECTRONICA) (pp 1–4). IEEE. <https://doi.org/10.1109/electronica52725.2021.9513662>

Veerendra, G. T. N., Kumaravel, B., Rao, P. K. R., Dey, S., & Manoj, A. V. P. (2023). Forecasting models for surface water quality using predictive analytics. *Environment Development and Sustainability*, 26(6), 15931–15951. <https://doi.org/10.1007/s10668-023-03280-3>

Wee, R. Y. (2019, March 18). *Top countries for aquaculture production*. WorldAtlas. <https://www.worldatlas.com/articles/top-15-countries-for-aquaculture-production.html>